



Brema Ice Machines add a touch of elegance to your establishment. Known and trusted in the industry for high-quality construction and consistent production, they are the most reliable choice for all your ice production needs.

Ice Flakes



Brema Ice Flake Machines are used in retail, fish and seafood, and therapeutic sectors for chilled displays and presentations. The auger and ice breaker work together to create irregular shapes in a continuous fashion. The simplicity of the production process ensures cost-effective operation.



Granular Ice, 80-82% Dry

Standard Features



1L water = 1kg ice



AISI 304 Stainless steel evaporator



Air cooling system



Easy cleanable internal rounded surfaces



Dust-proof water basin



RoHS Free



Electromechanical operation



ON/OFF switch



Automatic water charge



HFC Free
HC R290 Refrigerant Gas



GB Series

Standard Features Included



Adjustable stainless steel feet



GB903A HC



GB1504A HC

Brema Ice Machine Cleaner

For use with Brema Ice Machines to completely descale and clean interior and exterior surfaces and components. Colorless and odorless, powdered agent. Sold separately.



HCFC-Free insulated storage



Retractable insulated door

G Series

Standard Features Included



1 m³ = 550 kg of ice



Rotation sensor on low speed shaft



G160A HC



G280A HC



BIN200

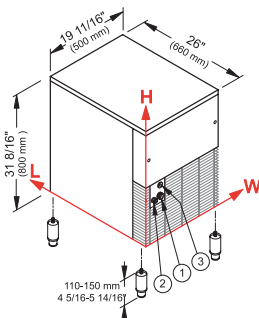

Adjustable feet 4 5/16" – 5 14/16"

GB903A HC

Power	115V, 450W, 4.5A
Compatible With	—
Production/24h*	253 lbs
Production/24h**	209 lbs
Bin Capacity	66 lbs
Dimensions (L x W x H)	26" x 19.5" x 31.5"
Net weight	148 lbs
Ship Dim. (L x W x H)	29" x 30.75" x 40"
Ship weight	167.5 lbs

Power	115V, 450W, 4.5A
Compatible With	—
Production/24h*	253 lbs
Production/24h**	209 lbs
Bin Capacity	66 lbs
Dimensions (L x W x H)	26" x 19.5" x 31.5"
Net weight	148 lbs
Ship Dim. (L x W x H)	29" x 30.75" x 40"
Ship weight	167.5 lbs

- ① WATER IN: 3 14/16" – 6 4/16" – 3/4"
- ② WATER OUT: 1 14/16" – 5 15/16" – 15/16"
- ③ ELECTRICAL CONNECTIONS: 3 7/16" – 9 1/16"

GB1504A HC

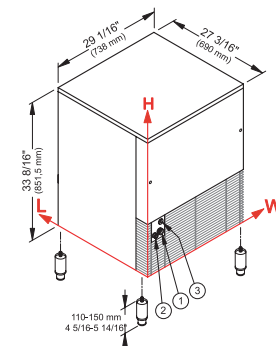

Adjustable feet 4 5/16" – 5 14/16"

Power	115V, 680W, 15A
Compatible With	—
Production/24h*	368 lbs
Production/24h**	335 lbs
Bin Capacity	88 lbs
Dimensions (L x W x H)	27" x 29" x 36"
Net weight	187 lbs
Ship Dim. (L x W x H)	29" x 30.75" x 46.5"
Ship weight	209 lbs

Power	115V, 680W, 15A
Compatible With	—
Production/24h*	368 lbs
Production/24h**	335 lbs
Bin Capacity	88 lbs
Dimensions (L x W x H)	27" x 29" x 36"
Net weight	187 lbs
Ship Dim. (L x W x H)	29" x 30.75" x 46.5"
Ship weight	209 lbs

- ① WATER IN: 4 2/16" – 7 3/16" – 3/4"
- ② WATER OUT: 2 1/16" – 6 14/16" – 15/16"
- ③ ELECTRICAL CONNECTIONS: 3 10/16" – 10"

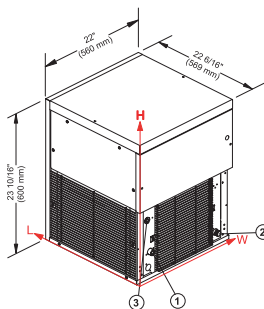

G160A HC

Power	115V, 665W, 5.8A
Compatible With	BIN100
Production/24h*	380 lbs
Production/24h**	368 lbs
Bin Capacity	—
Dimensions (L x W x H)	22.4" x 22" x 23.6"
Net weight	139 lbs
Ship Dim. (L x W x H)	25.4" x 25.4" x 32"
Ship weight	163 lbs

Power	115V, 665W, 5.8A
Compatible With	BIN100
Production/24h*	380 lbs
Production/24h**	368 lbs
Bin Capacity	—
Dimensions (L x W x H)	22.4" x 22" x 23.6"
Net weight	139 lbs
Ship Dim. (L x W x H)	25.4" x 25.4" x 32"
Ship weight	163 lbs

- ① WATER IN: 3 3/16" – 4 12/16" – 3/4"
- ② WATER OUT: 18 14/16" – 2 9/16" – 15/16"
- ③ ELECTRICAL CONNECTIONS: 2 11/16" – 11 7/16"

G280A HC

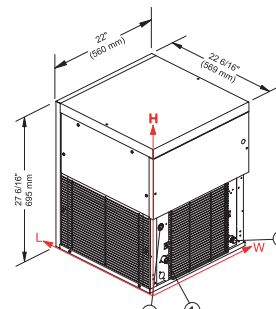

Power	120V, 1050W, 8.5A
Compatible With	BIN200
Production/24h*	668 lbs
Production/24h**	529 lbs
Bin Capacity	—
Dimensions (L x W x H)	22" x 22" x 27.5"
Net weight	183 lbs
Ship Dim. (L x W x H)	25.5" x 25.5" x 36"
Ship weight	205 lbs

Power	120V, 1050W, 8.5A
Compatible With	BIN200
Production/24h*	668 lbs
Production/24h**	529 lbs
Bin Capacity	—
Dimensions (L x W x H)	22" x 22" x 27.5"
Net weight	183 lbs
Ship Dim. (L x W x H)	25.5" x 25.5" x 36"
Ship weight	205 lbs

- ① WATER IN: 3 3/16" – 4 12/16" – 3/4"
- ② WATER OUT: 18 14/16" – 2 9/16" – 15/16"
- ③ ELECTRICAL CONNECTIONS: 2 11/16" – 11 7/16"

BIN200

Power	—
Compatible With	G280A HC
Production/24h*	—
Production/24h**	—
Bin Capacity	440 lbs
Dimensions (L x W x H)	31" x 34" x 39.5"
Net weight	163 lbs
Ship Dim. (L x W x H)	33" x 36.25" x 47.5"
Ship weight	205 lbs

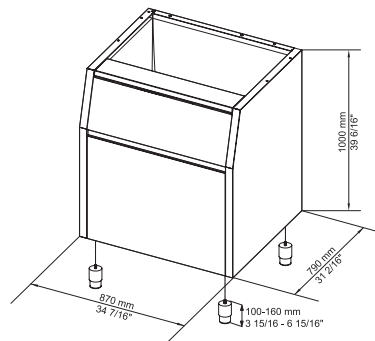

Adjustable feet 3 15/16" – 6 15/16"

*Ambient Temperature
21°C (70°F) / Water 10°C (50°F)
**Ambient Temperature
32°C (90°F) / Water 21°C (70°F)



Warranty
3 years parts & labor,
5 years on the compressor